

Operating instruction - Spindle lifting system SL/SM compact

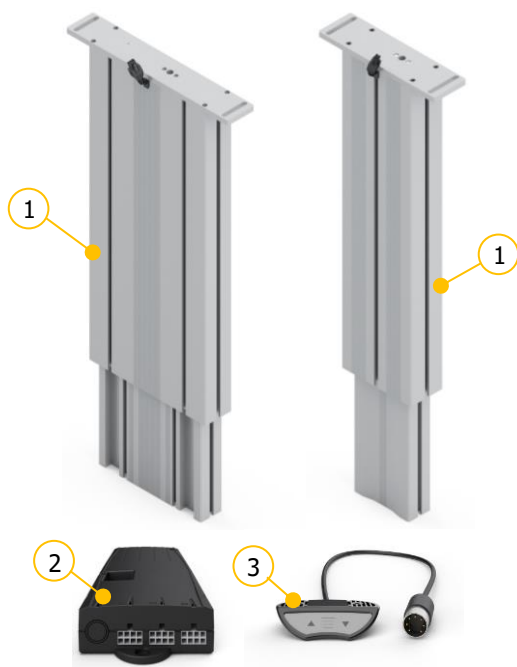

It is essential to read this operating instruction thoroughly before commissioning the system. This operating instruction has to be stored in the immediate vicinity of the system.



- ① Spindle lifting column type SL or SM
- ② Control box compact-3-eco
- ③ Manual control switch Up/Down or memory

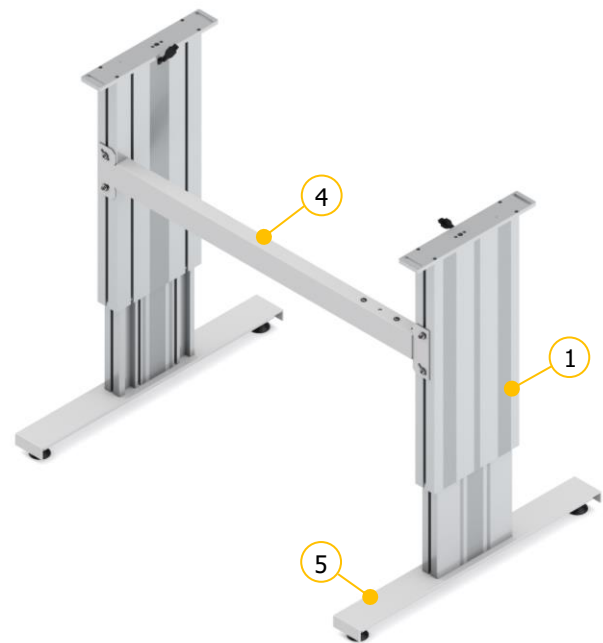

- Example of a table frame with two lifting columns
- ④ Cross bar
 - ⑤ Table feet

Errors and technical changes reserved.

Ergoswiss AG does not assume any liability for operating errors or using the products outside of the intended purpose use.

At the time of delivery Ergoswiss AG will replace or repair defect products within accordance with the warranty provisions. In addition, Ergoswiss assumes no other liability.

For your questions and special custom demand Ergoswiss AG will be at your disposal.

Ergoswiss AG

Nöllenstrasse 15
CH-9443 Widnau
Tel.: +41 (0) 71 727 06 70
Fax: +41 (0) 71 727 06 79

info@ergoswiss.com
www.ergoswiss.com

This operating instruction applies to:

Lifting systems SL

Example: Lifting system SL 2440 EU 01 (Article number: 901.20024)

	Description	Standard version
SL:	Lifting column type	SL, SM
2440:	Number of lifting columns	1, 2, 3
2440:	Spindle pitch in mm	3 mm, 4 mm
2440:	Stroke length in cm	30 cm, 40 cm
EU	Power cable	EU, CH, IT, UK, US
01	01= Manual control switch Up / Down ; 02= Memory	01, 02 -> (compact)

Lifting systems SM

Example: Lifting system SM 2440 EU 01 (Article number: 902.20024)

	Description	Standard version
SM:	Lifting column type	SL, SM
2440:	Number of lifting columns	1, 2, 3
2440:	Spindle pitch in mm	3 mm, 4 mm
2440:	Stroke length in cm	30 cm, 40 cm
EU	Power cable	EU, CH, IT, UK, US
01	01= Manual control switch Up / Down ; 02= Memory	01, 02 -> (compact)

Table of content

1	System description	4
1.1	General.....	4
1.2	Intended purpose use	4
1.3	Target group and prior knowledge	4
1.4	Performance characteristics	5
1.4.1	Lifting column SL 14xx.....	5
1.4.2	Lifting column SM 14xx.....	5
1.4.3	Motor SL/SM 24 V	5
1.4.4	Control box compact-3-eco	5
1.4.5	Manual control switch Up / Down and Memory.....	5
2	Safety requirements	6
2.1	Explanations of the symbols and notes	6
2.1	Basic safety instructions	7
3	Preparation for first initial operation	8
3.1	Mounting the control box and connecting the cables	8
3.2	Mounting of the manual control switch	10
3.2.1	Manual control switch Up / Down Front	10
3.2.2	Manual control switch Up / Down Touch.....	10
3.2.3	Manual control switch Memory	11
3.2.4	Manual control switch Memory Touch.....	11
4	Initial operation	12
4.1	Plug detection	12
5	Operation	13
5.1	Drive up / down	13
5.2	Duty cycle monitoring	13
5.3	Saving a memory position (Only with manual control switch type Memory!)	13
5.4	Approaching a stored position (Only with manual control switch type Memory!)	13
5.5	Setting the shown height on the display (Only with manual control switch type Memory!)	14
5.6	Container-Stop and Shelf-Stop-positions	14
5.7	Reset of the control box	15
5.7.1	Redefine end positions.....	15
5.7.2	Reset control box to factory settings («S 0») (Only with manual control switch type Memory!).....	15
6	Synchronous operation of 2, 3 or 4 control boxes	16
6.1	Cable connections.....	16
6.2	Commissioning the synchronized systems	17
6.3	Operation scenarios - FAQ.....	17
7	Safety strip - Squeezing protection.....	18
7.1	Technical Data	18
7.2	Connecting the safety strip	19
8	Maintenance and disposal	20
8.1	Maintenance and cleaning	20
8.2	Repairs and spare parts	20
8.3	Disassembly and disposal	20
8.4	Electrical and Electronic Equipment Act.....	20
8.5	Error messages on the display (Only with manual control switch type Memory!).....	21
8.6	Click codes.....	22
8.7	Trouble-shooting	22
9	Declaration of Incorporation	23

1 System description

1.1 General

The basic functionality of a spindle lifting system SL/SM by Ergoswiss AG is the lifting and lowering of work surfaces, machine parts, profile systems, etc.

An operative spindle lifting System SL/SM consists of a minimum of following components:

- Lifting column (with integrated spindle drive)
- Control unit (control box, manual control switch and power cable)

The lifting column SL/SM consists of two colorless anodized aluminium profiles which are guided with plastic guides. The inner profile is moved by an inline spindle drive. Up to 3 spindle lifting columns can be connected to one control box compact-3-eco and be operated synchronously.

The intelligent control box compact-3-eco is equipped with a highly efficient switched-mode power supply (SMPS) and a monitoring software (overload, duty cycle, overheat). Due to the optimised driving comfort, the end positions are gently approached as low-speed zones up to the standstill. Additional functions, such as the synchronisation of two to four control boxes or the connection of safety strips (squeezing protection) can be used.

With the manual control switch Up / Down the spindle lifting system can be operated comfortably, the work surface will be adjusted steplessly in its height.

With the separately available manual control switch Memory the hydraulic system can be operated comfortably, the work surface will be adjusted steplessly in its height. The current height of the work surface is continuously shown on the display (cm or inches). Up to four different memory positions can be stored and approached individually.

1.2 Intended purpose use

The lifting system SL/SM is used in applications which need ergonomic height adjustable work surfaces.

While mounting the lifting system into a greater system and while operating the system, the specified normal operation of the entire system is to be complied with. Commissioning is prohibited until the entire system complies with the provisions of EG Machinery Directives 2006/42/EG (Machinery Directive).

The system is only to be installed and used indoors in dry conditions.

The operating temperature range is at 0 °C to +40 °C.

The spindle lifting system must not be overloaded. Do not exceed the given maximum lifting load per lifting column.

The lifting system can be continuously operated for a maximum of 2 minutes. Afterwards a pause of at least 18 minutes needs to be observed before the system can be operated again. To avoid overheating of the system a duty cycle of 2/18 (ON/OFF) should be maintained in general.

1.3 Target group and prior knowledge

This operating instruction addresses the following groups of people:

The **commissioning staff**, who installs and commissions the lifting system into a work station, a machine, ect. For commissioning activities, mechanical and electrical knowledge is prerequisite. Before using the system for the first time the operating instruction must be read.

The **end user** controls the complete system via manual control switch and adjusts its height. Before using the system for the first time the operating instruction must be read.

1.4 Performance characteristics

1.4.1 Lifting column SL 14xx

Max. allowed pressure load	2'000 N	
Max. allowed tensile load	F _{tensile} stat. 500 N	F _{tensile} dyn. 50 N
Max. stat. bending moment	M _{bx} stat. 450 Nm	M _{by} stat. 1'200 Nm
Max. dyn. Bending moment	M _{bx} dyn. 200 Nm	M _{by} dyn. 550 Nm

1.4.2 Lifting column SM 14xx

Max. allowed pressure load	2'000 N	
Max. allowed tensile load	F _{tensile} stat. 500 N	F _{tensile} dyn. 50 N
Max. stat. bending moment	M _{bx} stat. 350 Nm	M _{by} stat. 900 Nm
Max. dyn. Bending moment	M _{bx} dyn. 150 Nm	M _{by} dyn. 450 Nm

1.4.3 Motor SL/SM 24 V

Nominal voltage	24 V
Nominal torque	3 Nm
Idle speed	150 min ⁻¹
Nominal power	92 W
Nominal current	4 A (no-load current 3 A)
Protection class (DIN EN 60529)	IP 30

1.4.4 Control box compact-3-eco

Supply voltage	EU: 207 - 254.4 V / 50 Hz	US: 90 – 127 V / 50-60 Hz
Primary standby power	<0.6 W	
Power	83% @ 300 W Input power	
Hall sensors supply voltage	5 VDC +/- 10 %; 250 mA	
Ambient temperature	0 – 40 °C	
Humidity	5 – 85 % (not condensating)	
Protection class (DIN EN 60529)	IP 20	
Performance level (DIN EN 13849-1)	PL b	
Dimensions (L, B, H)	264 x 103 x 37 mm	

1.4.5 Manual control switch Up / Down and Memory

Supply voltage	5 VDC ± 10 %
Power consumption (average)	50 mA
Ambient temperature	0 – 50 °C
Protection class (DIN EN 60529)	IP 30

2 Safety requirements

2.1 Explanations of the symbols and notes

Please pay attention to the following explanations of the symbols and notes. They are classified according to ISO 3864-2.

DANGER



Indicates an immediate threatening danger.
Non-compliance with this information can result in death or serious personal injuries (invalidity).

WARNING



Indicates a possible dangerous situation.
Non-compliance with this information can result in death or serious personal injuries (invalidity).

ATTENTION



Indicates a possible dangerous situation.
Non-compliance with this information can result in damage to property or light to medium personal injuries.



NOTE

Indicates general notes, useful operator advice and operating recommendations which do not affect safety and health of the user.

2.1 Basic safety instructions

The safety instructions must be paid attention to. If the system is operated improperly, it can cause danger to people and objects!

It is essential to read this operating instruction thoroughly before commissioning the system. This operating instruction has to be stored in the immediate vicinity of the system.

- In no case the control box may be opened! There is the risk of an electrical shock.
- Modifications or changes to the control box, the manual control switch, the motor and any connection cables are forbidden!
- The control box must only be operated with mains voltage indicated on the name plate!
- The supplied power cable must be used. It is forbidden to operate the control box with a damaged power cable!
- Electrical cables must not be exposed to crushing hazard or to bending and tensile loads.
- Before connecting/disconnecting the manual control switch the power cable has to be disconnected from the mains!
- The control box must not be operated in a potentially explosive atmosphere!
- The control box must be protected from moisture, dripping water as well as spray water!
- The control box is not suitable for continuous use. The operation/hold ratio must not exceed 2/18.
- If there is a failure (for example, if the control drives on its own, or if a push button is stuck) the power cable is to be separated from the mains immediately! The power cable must be freely accessible at any time.
- While using the height adjustment of the work surface there is a danger of squeezing. It is important to make sure that no objects or people are within the danger zone and no one is reaching into the danger zone.
- This device is not intended to be used by people (including children under 8) with restricted physical, sensory or mental abilities or with a lack of experience and/or knowledge, unless they are supervised by a person responsible for safety or they have received instructions by this very person on how to operate the device.
- Children under 8 should be supervised to ensure that they do not play with the device.
- If the power cable of the drive is damaged it must be replaced by the manufacturer, the manufacturer's customer service or by a similar qualified person.
- Only use a dry or a damp cloth to clean the control box! Before cleaning, the power cable has to be separated from the mains!

3 Preparation for first initial operation

Before commissioning the lifting system, the entire system must be assembled correctly according to the assembly instruction. Commissioning is prohibited until the entire system complies with the provisions of EG Machinery Directives 2006/42/EG. For this, a risk analysis of the complete system must be carried out so that you can react to possible residual dangers (for example by constructive measures or by instructions in the operating instructions and/or by safety instructions on the system).

3.1 Mounting the control box and connecting the cables

Mounting of the control box underneath a table top:

ATTENTION



During mounting of the control box the power cable needs to be disconnected from the mains!

1. Place the control box to the desired location and mark the drill holes with a pen.

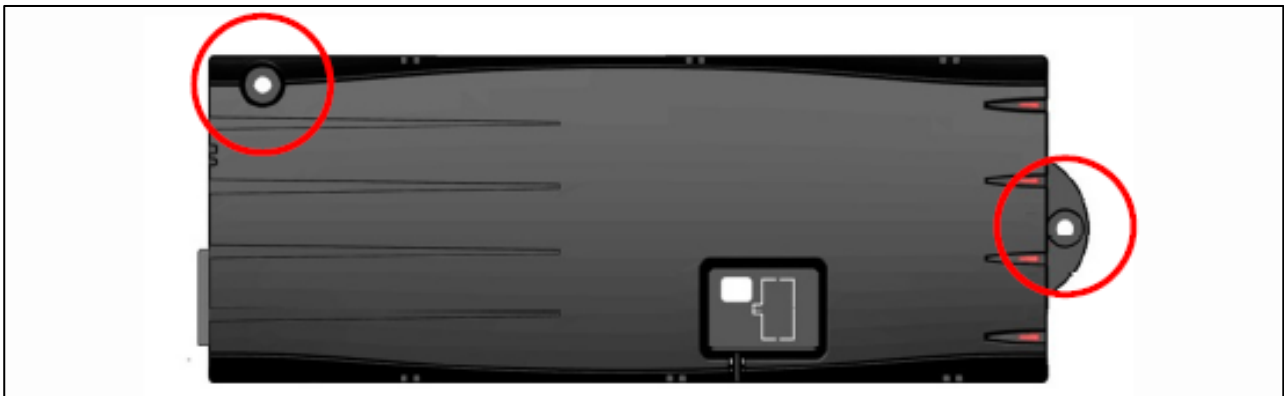

2. Pre-drill two holes (\varnothing 3 mm).
Be careful not to drill through the table top!
3. The control box is mounted with two screws (cap screws DIN7981C 4.8xL, cap- \varnothing 9.5 mm).



NOTE

When tightening the screws do not exceed a maximum torque of 2 Nm!



NOTE

The motor cable, connecting the control box to the motor, has a length of 1'750 mm. If needed, up to 5 motor extension cables can be connected. They have a length of 1'200 mm.
→ 124.00137: PXD compact Extension cable 1'200 mm Motor



NOTE

The cable of the manual control switch has a length of 1'800 mm. If needed it can be expanded with up to 3 extension cables. They have a length of 1'000 mm.
→ 124.00071: PXD Extension cable 1'000 mm Manual control switch

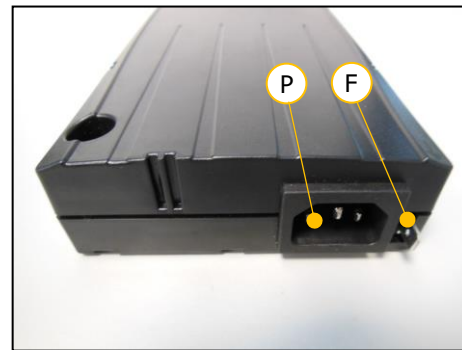
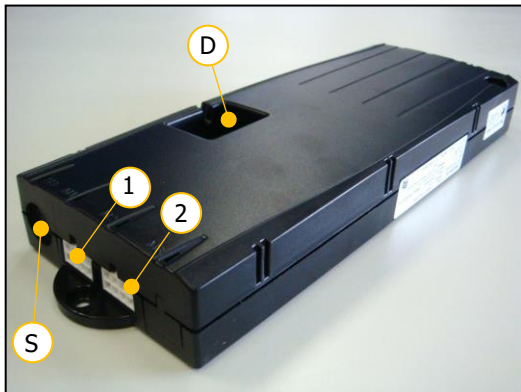

- | | | | |
|-----|----------------------------------|-----|--|
| ① | Motor socket 1 (M1) | (D) | Connection for safety strip or sync cable |
| ② | Motor socket 2 (M2) | (P) | Power socket |
| (S) | Socket for manual control switch | (F) | Connection for functional grounding (e.g. ESD) |

ATTENTION



Connecting homemade products to the control box is prohibited!
Only use supplied components.

1. Connect the motor cables to the control box. (Automatic plug detection)
2. Connect the manual control switch to the control box.
3. Connect the power cable to the control box.
4. Connect power cable to the mains. (Clicking sound → ready for initial operation)

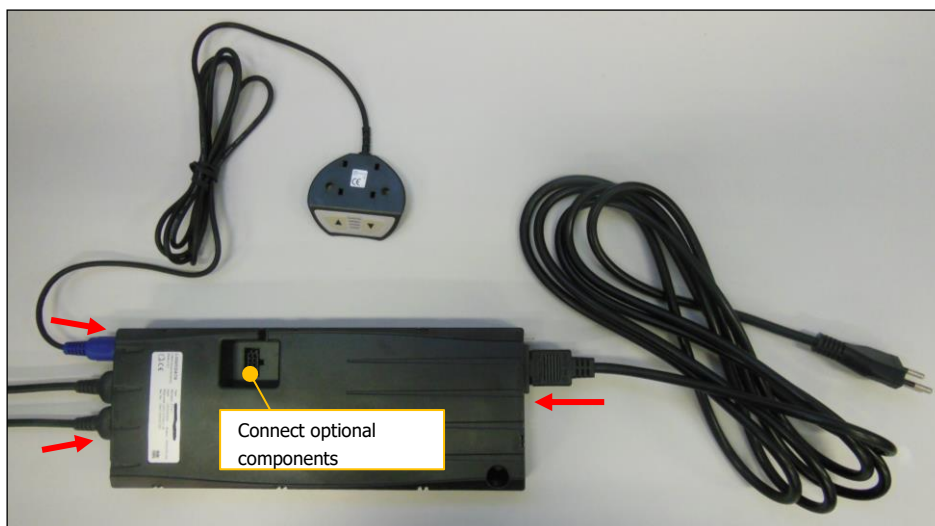

NOTE

- Before connecting the power cable to the mains the following must be verified:
- Does the mains voltage correspond to the value on the name plate of the control box?
 - Are the plugs of the motor cable connected to the correct sockets (M1, M2)?
 - Is the entire lifting system assembled according to the assembly instructions?

3.2 Mounting of the manual control switch

3.2.1 Manual control switch Up / Down Front

1. Position the manual control switch at the desired location underneath the table top.
The control panel must overhang below the work surface!
2. Fasten the manual control switch using the mounting screws.
Be careful not to drill through the table top!

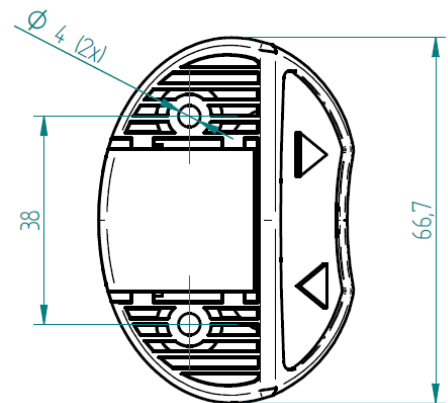
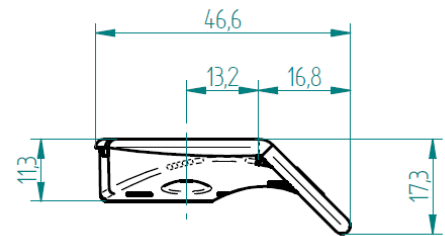

3.2.2 Manual control switch Up / Down Touch

1. Position the manual control switch at the desired location underneath the table top.
The control panel must overhang below the work surface!
2. Fasten the manual control switch using the mounting screws.
Be careful not to drill through the table top!

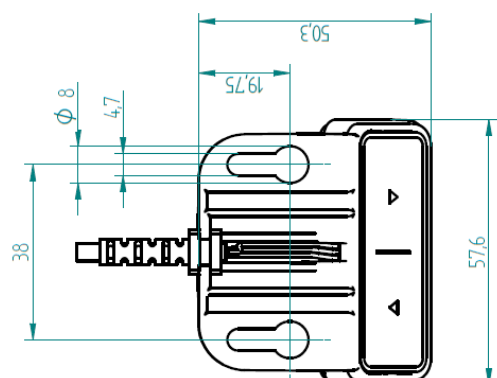
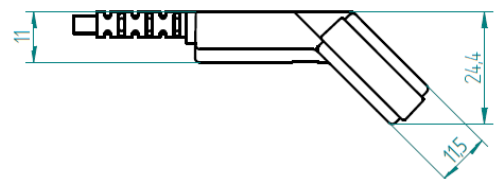

3.2.3 Manual control switch Memory

1. Position the mounting plate underneath the table plate.
The control panel must overhang below the work surface!
2. Fasten the mounting plate using the mounting screws.
Be careful not to drill through the table top!
3. Slide the manual control switch onto the mounting plate.

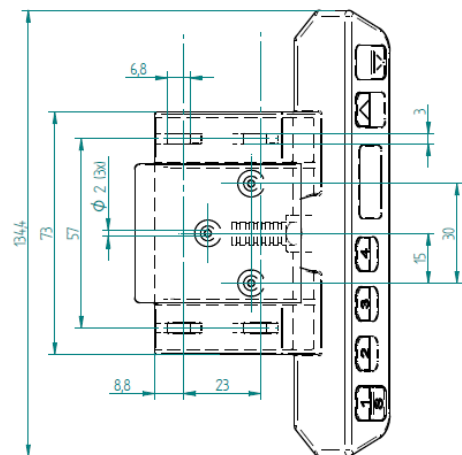
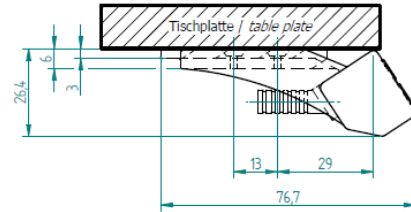

3.2.4 Manual control switch Memory Touch

1. Position the manual control switch at the desired location underneath the table top.
The control panel must overhang below the work surface!
2. Fasten the manual control switch using the mounting screws.
Be careful not to drill through the table top!

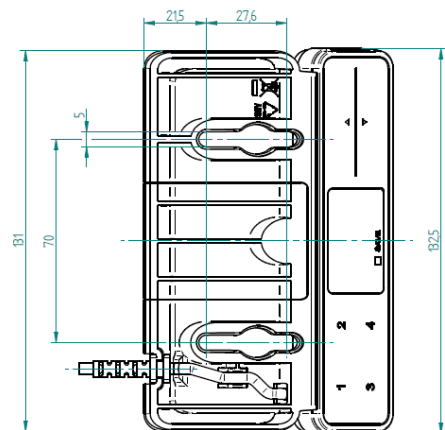
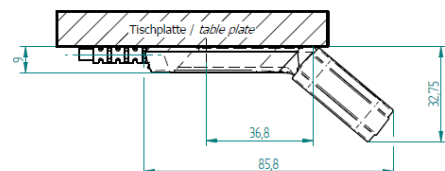

4 Initial operation

ATTENTION



Before commissioning the lifting system, the entire system must be assembled correctly according to the assembly instruction. Commissioning is prohibited until the entire system complies with the provisions of EG Machinery Directives 2006/42/EG. For this, a risk analysis of the complete system must be carried out so that you can react to possible residual dangers (for example by constructive measures or by instructions in the operating instructions and/or by safety instructions on the system.)

ATTENTION



While using the height adjustment of the work surface there is a danger of squeezing. It is important to make sure that no objects or people are within the danger area and no one is reaching into the danger zone.

ATTENTION







The lowest block position must always be reachable. The lifting element is not allowed to hit a stop before it reached its lowest block position. Otherwise the reference will be stored at a wrong height.



NOTE

During the initial operation the control box works with only half power and half speed. The system should be fully loaded after finishing the initial operation.

1. Keep the buttons  and  pressed simultaneously to drive to the under block position. The system moves downwards at half speed. Upward movement is disabled.
 2. After reaching the block position, let go of the buttons  and .
- The control box will give a click-sound and the system will drive out a few millimeters.

After reaching the block position, the lower and the upper position will be stored automatically. The initial operation is completed.

(The lower position is 3 to 4 mm higher than the block position. The upper position depends of the lifting element type, resp. of the control box software.)

4.1 Plug detection

The control box can detect whether a lifting element is plugged into the relevant socket. In addition, the control box detects whether a lifting element has been replaced.



If a lifting element is missing or if it is replaced, the control box will click three times.

After plugging out a lifting element the system must be reset to synchronize all connected lifting elements.

5 Operation

5.1 Drive up / down

This function is used for easy height adjustment of the system.

- Press the button  or .
Keep the button pressed until the desired working height is reached.

5.2 Duty cycle monitoring

The duty cycle monitoring checks for the operation/hold ratio. To avoid overheating of the system a duty cycle of 2/18 (ON/OFF) should be maintained.

The maximum continuous operating time is 2 minutes. Afterwards a pause of at least 18 minutes needs to be observed before the system can be operated again.

5.3 Saving a memory position (Only with manual control switch type Memory!)

With this function it is possible to memorise a certain position/height and approach it at a later time by pushing one button. With the four memory buttons up to four different positions can be stored and approached.

1. Drive to the desired position and press the button  (Save).

Display: 

2. Press one of the buttons    .
- After pressing a memory button the display shows «S» and the number of the pressed button.





Example: 

After saving there is a double click sound, and after approx. 2 seconds the current height is displayed again.

Example: 

5.4 Approaching a stored position (Only with manual control switch type Memory!)

This function is designed to approach a stored position.

- Keep one of the buttons     pressed.
The system approaches and stops at the stored position.

5.5 Setting the shown height on the display **(Only with manual control switch type Memory!)**



The displayed height can be adjusted with this feature.

1. Drive to any desired height and press the button  (Save).

Display: 

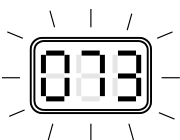
2. Keep the button  pressed for about 5 seconds, until the display starts flashing.

Example: 

3. Now the button  (plus) or  (minus) can be used to set the current height. While doing so, the system does not move!
4. With the correctly set value the new height is saved by pressing  (Save).



5.6 Container-Stop and Shelf-Stop positions

These two features can be used to limit the movement area of the lifting system (e.g. if a container is placed underneath the desktop).



A Container-Stop position can be defined in the lower half of the movement area, this position will be the new lowest end position.

A Shelf-Stop position can be defined in the upper half of the movement area, this position will be the new highest end position.

To define a Container-Stop/Shelf-Stop position, proceed as follows:

1. Drive to the desired end position in the lower half (for Container-Stop) or in the upper half (for Shelf-Stop) of the movement area.
2. Keep the buttons  and  pressed simultaneously for 10 seconds. Control box will **click twice** when position is stored.

To deactivate a Container-Stop/Shelf-Stop position, proceed as follows:

1. Drive to the stored end position (Container-Stop/Shelf-Stop position).
2. Keep the buttons  and  pressed simultaneously for 10 seconds. Control box will **click once** when position is deactivated.



NOTE







For a Container-Stop position and Shelf-Stop position, these steps must be performed separately.

5.7 Reset of the control box

5.7.1 Redefine end positions

1. Drive the system to the programmed lowest position.
2. Keep the button  pressed for 5 seconds («Long Key Down»).
System will drive to the lower block position and adjust itself like during the initial operation.

5.7.2 Reset control box to factory settings («S 0») **(Only with manual control switch type Memory!)**

1. Press the buttons ,  and  simultaneously, until «S 5» or «S 7» is displayed.
2. Press the button  until «S 0» appears on the display.
3. Press the button  (Save).
Control box clicks 3 times and the display shows «E70»!
4. Disconnect power cable and wait for at least 5 seconds.
5. Connect the power cable.
The display is flashing «000»!
6. Keep the button  pressed for 5 seconds («Long Key Down»).
The system moves downwards at half speed until the block position is reached.

6 Synchronous operation of 2, 3 or 4 control boxes

6.1 Cable connections

Up to three lifting elements can be connected to one control box compact-3-eco. By cascading multiple control boxes they can be controlled simultaneously with just one manual control switch. The control boxes can be connected using the PXD SYNC-2 cable (124.00088) or the PXD SYNC-4 cable (124.00089).

PXD SYNC-2 cable



With the SYNC-2 cable two control boxes PXD compact can be connected and synchronised.

→ The length of the SYNC-2 cable is 550 mm.

The SYNC cable cannot be extended. If necessary, the motor cables can be extended!



NOTE

Always do reset before disconnecting!

Disconnect plug carefully -> risk of damage

PXD SYNC-4 cable



With the SYNC-4 cable 2, 3 or 4 control boxes PXD compact can be connected and synchronised.

→ The length of SYNC-4 cable is 1'800 mm

→ Two connected SYNC-4 cables have a length of 2'000 mm

Each control box needs one SYNC-4 cable.

The SYNC cable cannot be extended. If necessary, the motor cables can be extended!



The SYNC-4 cables of each control box are to be connected.

→ The loose ends do not have to be connected. However, connecting the loose ends will not have any influence to the system.

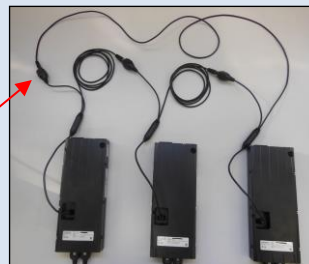

6.2 Commissioning the synchronized systems

1. Wire the drives according to instructions.
2. Connect the control boxes using the PXD SYNC-2 cable for two control boxes, or the PXD SYNC-4 cable for 2, 3 or 4 control boxes.
3. Only one manual control switch is necessary. The control box with the manual control switch is the **master control box**. All other control boxes are subordinated.
4. Connect the control boxes to the mains.
(Clicking sound of the control box → ready for initial operation)
5. Carry out the initial operation according to chapter 4.

ATTENTION



The SYNC cable must be connected to the control box before the control box is connected to the mains. If the SYNC cables are connected afterwards, they will not be recognised by the control box and only one drive will move, which can lead to jamming of the entire system.



NOTE

When disconnecting the SYNC cable uncarefully, the plug can be ripped out of the print platine!

6.3 Operation scenarios - FAQ

Scenario: connecting the manual control switch to another control box

- Display blinks «- - -«
- Manual control switch doesn't work
- Manual control switch ONLY works on the the master control box

Scenario: disconnecting or reconnecting the synchronisation cable

- Display blinks «000»
- Then display blinks «E93»
- Perform a Reset «S 0» according to chapter 5.7.2 (all controls are reset to factory settings)

Scenario: power cut

- Control box saves all stored positions
- Synchronisation is stored
- Getting back the power, the system can be used as usual. No initial operation necessary.

Scenario: power cut on only one control box

- Display blinks «000»
- Then display blinks «E93»
- Perform a Reset «S 0» according to chapter 5.7.2 (all controls are reset to factory settings)

7 Safety strip - Squeezing protection

With lifting systems of Ergoswiss AG it is important to make sure that no objects or people are trapped during the lifting movement. ->**Danger of squeezing**

Attach the safety strip to an assumed squeeze zone. If the safety strip gets squeezed while the system moves, the motor will stop instantly and turn back for one motor turn (4 mm).

The safety strip compact cpl. (124.00105) consists of:

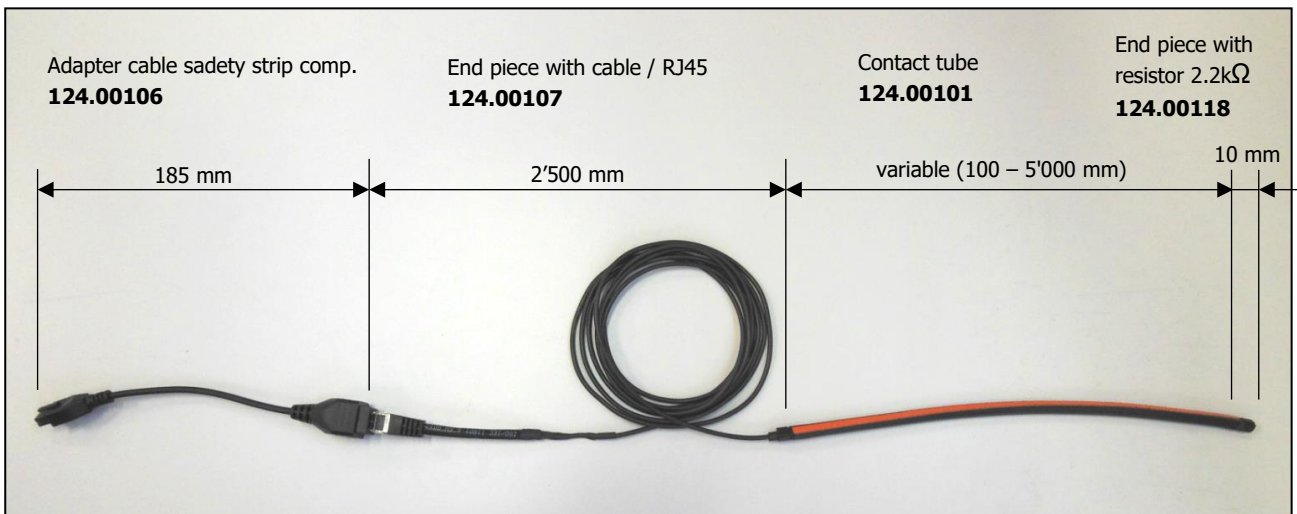

7.1 Technical Data

Functional properties of the contact tube

Contact angle	< 80 °
Switching pressure	< 25 N at 23 °C
Switching travel	< 2mm at 23 °C
Bending radii minimal	B ₁ 120 mm / B ₂ 150 mm / B ₃ 20 mm / B ₄ 20 mm
Max. tensile load	20 N

Electrical properties

Terminal resistance	2.2 kOhm
Max. switching capacity	250 mW
Max. Voltage	DC 24 V
Current min/max	1 mA / 10 mA

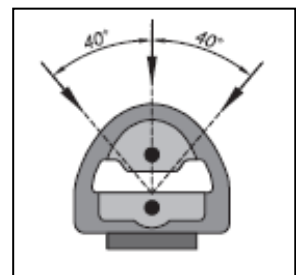
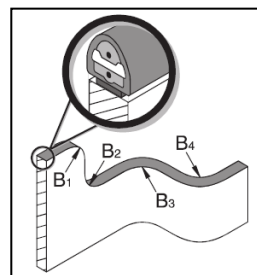

7.2 Connecting the safety strip

The safety strip compact is compatible with the control box compact.

When installing the system, up to two safety strips can be mounted and operated at a potential squeeze zone. The length of the contact tube can be freely selected from 0 to 5'000 mm of length.

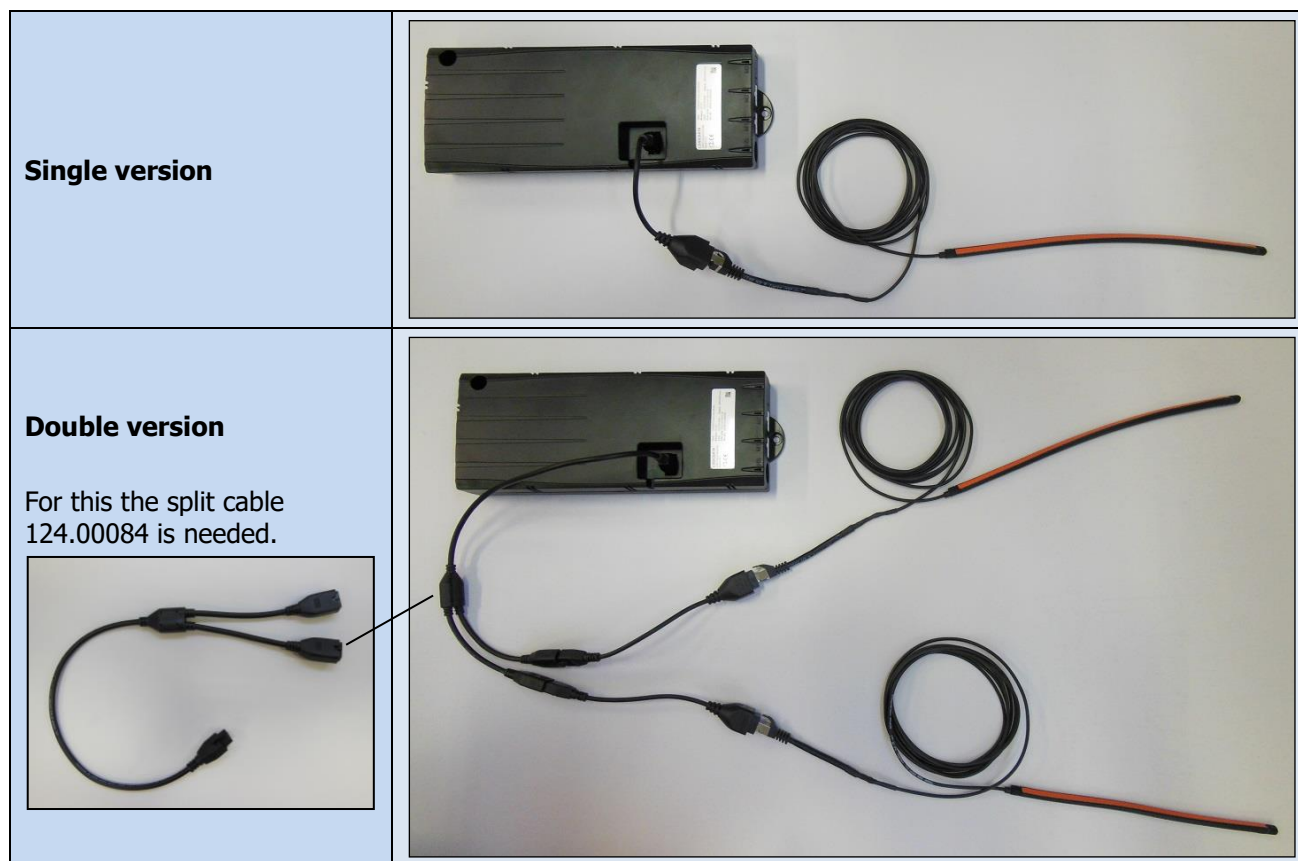

NOTE

If it is necessary to attach a PXD SYNC cable to the control box in addition to the safety strip, both can also be connected with the split cable.

Gluing the contact tube in the squeeze zone	Connecting the safety strip
<ol style="list-style-type: none"> 1. Clean and degrease the contact face 2. Pull off a liner of acrylic foam of 10 to 15 cm 3. Place it on the contact face and press on well 4. Repeat steps 2 and 3 until the contact tube is completely glued on 5. Maximum adhesion is reached after 24 h 	<ol style="list-style-type: none"> 1. Wire the drive according to instructions. 2. Run the cable 124.00107 orderly to avoid entanglement 3. Connect the adapter plug to the control box 4. The safety strip must be connected to the control box before the control box is connected to the mains.



NOTE

The safety strip must be connected to the control box before the control box is connected to the mains. If the safety strip is connected afterwards, it will not be recognised by the control box.

8 Maintenance and disposal

8.1 Maintenance and cleaning

The lifting system is maintenance-free for up to 10'000 cycles while observing the specified normal operation. Therefore, servicing is not necessary.

ATTENTION



The control box and the manual control switch must only be cleaned with a dry or damp cloth. Before cleaning the power cable has to be separated from the mains.

ATTENTION



No liquid is allowed to enter the plug connections.

8.2 Repairs and spare parts

Repairs must only be conducted by specialists. Only original replacement parts may be used. For all repair work the system must always be unloaded and voltage-free.

ATTENTION



In no case may the control box be opened! There is the risk of an electrical shock.



8.3 Disassembly and disposal

When decommissioning and disposing of the lifting system the electronic parts must be disposed of separately. The system consists of components that can be fully recycled and thus they are quite safe from an environmental protection perspective. The electronic parts comply with the RoHS directive.

8.4 Electrical and Electronic Equipment Act

The lifting system is not covered by the Electrical and Electronic Equipment Act (WEEE Directive 2012/19/EU), since the lifting system – in accordance with the intended purpose use – is not intended for end-users (business-to-customer) but for industrial applications (business-to-Business) is designed.

8.5 Error messages on the display (Only with manual control switch type Memory!)

Display	Cause	Rectification
	The control box compact is equipped with an overheating protection. This overheating protection will activate due to too high temperatures	Wait until the control box has cooled down and the message «HOT» is no longer displayed. Then the control box is ready for operation again.
	There is an internal error at the control box.	Proceed according to the following error list.
00	Internal error channel 1	Disconnect the power cable from the mains and contact the customer service.
01	Internal error channel 2	
12	Defective channel 1	Insert the motor cable correctly.
13	Defective channel 2	
24	Excess current motor M1	System overloaded → Remove load from the system
25	Excess current motor M2	
48	Excess current motor group 1	
49	Excess current motor group 2	
60	Collision protection	System jammed → remove clamped object
62	Excess current at the control	
36	Plug detection at motor socket M1	Plug in the motor cable correctly at the respective socket.
37	Plug detection at motor socket M2	
61	Motor replaced	Perform a reset.
55	Synchronising of the motor group 1 impossible	Remove load from the system. Perform a reset. Contact the customer service if the error remains displayed.
56	Synchronising of the motor group 2 impossible	
67	Too high voltage	Disconnect the power cable from the mains. Contact the customer service.
70	Change of the drive configuration	Disconnect the power cable from the mains and wait at least for 5 seconds. Reconnect the power cable and perform a reset.
81	Internal error	Disconnect the power cable from the mains and wait at least for 5 seconds. Reconnect the power cable and perform a reset. Contact the customer service if the error remains displayed.
93	Connection error while synchronising The error is displayed for 15 seconds, then the control box changes to the reset mode with a flashing display of «000».	Disconnect the power cable from the mains and wait at least for 5 seconds. Reconnect the power cable and perform a reset.

8.6 Click codes

As soon as the lifting system is supplied with current the control utilises the integrated relays to acoustically indicate the system state as well as the reason of the last shut down to the user.

Number of clicks	Status information
2x	Normal operation: The system works flawlessly.
1x	Emergency operation: The system is in emergency mode; the motors cannot be operated. There is an error code to be checked on the display.
3x – 6x	Last shut down incomplete / forced reset: There is an error code to be checked on the display.

8.7 Trouble-shooting

Error	Cause	Rectification
Drive does not work	Control box not connected	Connect power cable
	Motor not connected	Connect motor cable
	Motor defective	Contact the customer service
	Control box defective	Contact the customer service
	Manual control switch defective	Replace the manual control switch
	Bad connector contact	Plug in all plugs correctly
Drive only move to one direction	Control box defective	Contact the customer service
	Manual control switch defective	Replace the manual control switch
Drive only moves downwards	System overload	Remove weight from the system

9 Declaration of Incorporation

<p>ERGO SWISS table lift systems</p>	<p>Ergoswiss AG Nöllenstrasse 15 9443 Widnau Schweiz</p>	<p>Tel. +41 (0) 71 727 0670 Fax +41 (0) 71 727 0679 info@ergoswiss.com www.ergoswiss.com</p>
<p>EG-Declaration of Incorporation in the sense of the Machinery Directive 2006/42/EG annex II 1B</p>		
<p>We hereby declare that for the incomplete machine "spindle lifting system", for ergonomically height adjustable workplaces or similar, with the variants</p>		
<p>Lifting system SL xxxx compact Frame SL-x xxxx compact</p>	<p>(Art. Nr. 901.2xxxx) (Art. Nr. 901.3xxxx)</p>	
<p>Lifting system SM xxxx compact Frame SM-x xxxx compact</p>	<p>(Art. Nr. 902.2xxxx) (Art. Nr. 902.3xxxx)</p>	
<p>the following essential requirements of the Machinery Directive 2006/42/EG are applied and complied with:</p>		
<p>1.1.2.; 1.1.3.; 1.1.5.; 1.1.6.; 1.2.; 1.3.2.; 1.3.9.; 1.5.1.; 1.5.3.; 1.5.7.; 1.5.8.</p>		
<p>In particular the applied harmonized standards:</p>		
<p>EN 1005 EN ISO 12100 EN 55014 EN 60335 EN 60204 EN 61000 EN 62233</p>	<p>Safety of machinery: Physical performance Safety of machinery: 2011 Electromagnetic compatibility Safety of electrical appliances for household use Electrical equipment of devices Electromagnetic compatibility: EMC Houshold electrical appliances EMC, evaluation and measurement</p>	
<p>specific technical documentation have been created in accordance with annex VII, part B, and will be sent to the national authorities by registered letter or electronically, if the request is justified, and this incomplete machine is in conformity with the relevant provisions of other EU Directives:</p>		
<p>89/391/EG 2001/95/EG 2014/30/EU 2014/35/EU</p>	<p>Safety and health of workers General product safety Directive on electromagnetic compatibility Low voltage directive</p>	
<p>Furthermore, we declare that this incomplete machine may only be commissioned if it has been determined that the machine in which the incomplete machine is to be installed complies with the provisions of the Machinery Directive 2006/42/EG and our assembly and service operating instructions have been followed.</p>		
<p> Widnau, 28. February 2018 Martin Keller Managing Director / CEO</p>	<p>Document responsibility EU: Ergoswiss Deutschland GmbH Weiherstrasse 6/1 DE-72585 Riederich</p>	