

Operating instruction - Spindle lifting system SLA/SLG VD

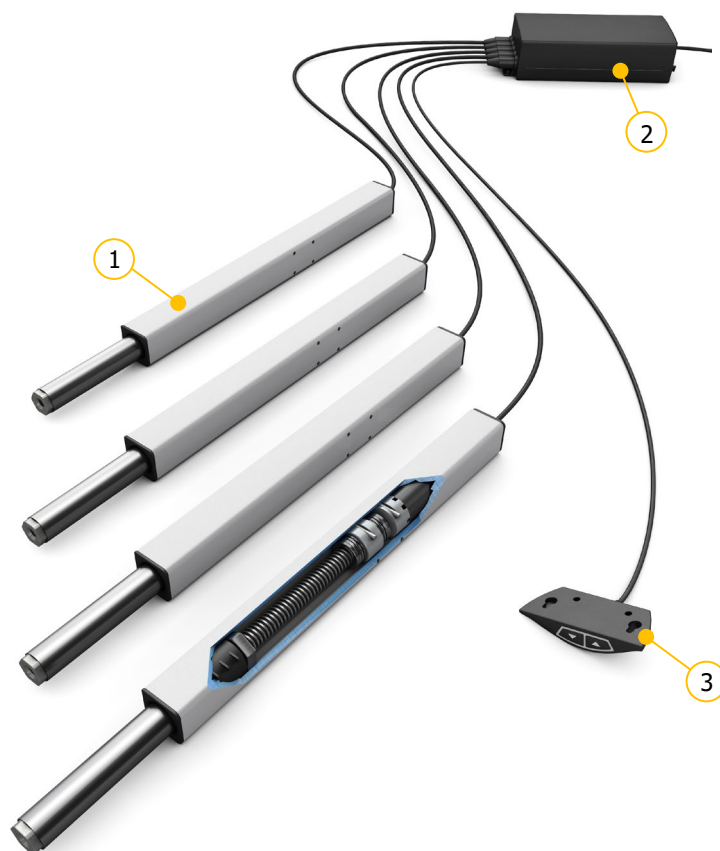

It is essential to read this operating instruction thoroughly before commissioning the system. This operating instruction has to be stored in the immediate vicinity of the system.



- ① Linear unit type SLA or SLG
- ② Control box VD SCT

- ③ Manual control switch Up/Down or Memory

Errors and technical changes reserved.

Ergoswiss AG does not assume any liability for operating errors or using the products outside of the intended purpose use.

At the time of delivery Ergoswiss AG will replace or repair defect products within accordance with the warranty provisions. In addition, Ergoswiss assumes no other liability.

For your questions and special custom demand Ergoswiss AG will be at your disposal.

Ergoswiss AG

Nöllenstrasse 15
CH-9443 Widnau
Tel.: +41 (0) 71 727 06 70
Fax: +41 (0) 71 727 06 79

info@ergoswiss.com
www.ergoswiss.com

This operating instruction applies to:

Lifting system SLA

Example: Lifting system SLA 4330 EU 11 (Item number: 903.20033)

	Description	Standard version
SLA:	Linear unit type	SLA, SLG
4330:	Number of linear units	1, 2, 3, 4
4330:	Spindle pitch in mm	3 mm
4330:	Stroke length in cm	30, 40 cm
EU	Power cable	EU, CH, IT, UK, US
11	11= manual control switch up/down ; 12= Memory	11, 12 -> (VD)

Lifting system SLG

Example: Lifting system SLG 4330 EU 11 (Item number: 904.20033)

	Description	Standard version
SLG:	Linear unit type	SLA, SLG
4330:	Number of linear units	1, 2, 3, 4
4330:	Spindle pitch in mm	3 mm
4330:	Stroke length in cm	30, 40 cm
EU	Power cable	EU, CH, IT, UK, US
11	11= manual control switch up/down ; 12= Memory	11, 12 -> (VD)

Table of content

1	System description	4
1.1	General	4
1.2	Intended purpose use	4
1.3	Target group and prior knowledge	4
1.4	Performance characteristics	5
1.4.1	Linear unit SLA 13xx	5
1.4.2	Linear unit SLG 13xx	5
1.4.3	Motor SX D30 24 V	5
1.4.4	Control box VD SCT2 and SCT4	5
1.4.5	Manual control switch VD Up / Down and memory	5
2	Safety requirements	6
2.1	Explanations of the symbols and notes	6
2.2	Basic safety instructions	7
3	Preparation for first initial operation	8
3.1	Mounting the control box and connecting the cables	8
3.2	Mounting of the manual control switch	10
3.2.1	Manual control switch VD Up / Down	10
3.2.2	Manual control switch VD / Memory	10
3.2.3	Manual control switch VD Memory T6	11
4	Initial operation	12
5	Operation	13
5.1	Drive up / down	13
5.2	Duty cycle monitoring	13
5.3	Saving a memory position (Only with manual control switch type Memory!)	13
5.4	Approaching a stored position (Only with manual control switch type Memory!)	13
5.5	Container-Stop and Shelf-Stop-positions (Only with manual control switch type Memory!)	14
5.5.1	Child-proof lock (Only with manual control switch type Memory!)	14
5.6	Reset of the control box	14
6	Synchronous operation of 2 control boxes	15
6.1	Cable connections	15
6.2	Commissioning the synchronized system	15
7	Safety strip - Squeezing protection	16
7.1	Technical Data	16
8	Maintenance and disposal	17
8.1	Maintenance and cleaning	17
8.2	Repairs and spare parts	17
8.3	Disassembly and disposal	17
8.4	Electrical and Electronic Equipment Act	17
8.5	Error messages on the display (Only with manual control switch type Memory!)	18
8.6	Trouble-shooting	19
9	Declaration of Incorporation	20

1 System description

1.1 General

The basic functionality of a spindle lifting system SLA/SLG by Ergoswiss AG is the lifting and lowering of work surfaces, machine parts, profile systems, etc.

An operative spindle lifting System SLA/SLG consists of a minimum of following components:

- Linear unit (with integrated spindle drive)
- Control unit (control box, manual control switch and power cable)

The housing of the linear unit SLA/SLG is made out of a colorless anodized aluminium profile. The steel piston pipe is guided in a plastic bushing and is moved by an inline spindle drive. Up to 4 linear units can be connected to one control box VD SCT4 and be operated synchronously.

The high-performance control box VD SCT is equipped with two or four motor channels, which are adjusted synchronously by an encoder converter. Due to the optimised driving comfort, the end positions are gently approached as low-speed zones up to the standstill. Additional functions, such as the synchronisation of two control boxes or the connection of safety strips (squeezing protection) can be used.

With the separately available manual control switch Memory the hydraulic system can be operated comfortably, the work surface will be adjusted steplessly in its height. The current height of the work surface is continuously shown on the display (cm or inches). Up to three different memory positions can be stored and approached individually.

1.2 Intended purpose use

The lifting system SLA/SLG is used in applications which need ergonomic height adjustable work surfaces. While mounting the lifting system into a greater system and while operating the system, the specified normal operation of the entire system is to be complied with. Commissioning is prohibited until the entire system complies with the provisions of EG Machinery Directives 2006/42/EG (Machinery Directive).

The system is only to be installed and used indoors in dry conditions.

The operating temperature range is at 0 °C to +40 °C.

The spindle lifting system must not be overloaded. Do not exceed the given maximum lifting load per linear unit.

The lifting system can be continuously operated for a maximum of 2 minutes. Afterwards a pause of at least 40 minutes needs to be observed before the system can be operated again. To avoid overheating of the system a duty cycle of 2/40 (ON/OFF) should be maintained in general.

1.3 Target group and prior knowledge

This operating instruction addresses the following groups of people:

The **commissioning staff**, who installs and commissions the lifting system into a work station, a machine, ect. For commissioning activities, mechanical and electrical knowledge is prerequisite. Before using the system for the first time the operating instruction must be read.

The **end user** controls the complete system via manual control switch and adjusts its height. Before using the system for the first time the operating instruction must be read.

1.4 Performance characteristics

1.4.1 Linear unit SLA 13xx

Max. allowed pressure load	1'500 N
Max. allowed tensile load	1'500 N
Max. stat. bending moment	150 Nm
Max. dyn. Bending moment	50 Nm

1.4.2 Linear unit SLG 13xx

Max. allowed pressure load	1'500 N
Max. allowed tensile load	1'500 N
Max. stat. bending moment	200 Nm
Max. dyn. Bending moment	80 Nm

1.4.3 Motor SX D30 24 V

Nominal voltage	24 V
Nominal torque	2.5 Nm
Idle speed	352 min ⁻¹
Nominal power	64 W
Nominal current	5.55 A (no-load current 0.33 A)

1.4.4 Control box VD SCT2 and SCT4

Supply voltage	EU: 207 - 254.4 V / 50 Hz	US: 90 – 127 V / 50-60 Hz
Primary standby power	< 0.5 W	
Power	280 VA (SCT2) ; 340 VA (SCT4)	
Ambient temperature	0 – 40 °C	
Humidity	5 – 85 % (not condensating)	
Protection class (DIN EN 60529)	IP 20	
Performance level (DIN EN 13849-1)	PL b	
Dimensions (L, B, H)	260 x 120 x 50 mm	

1.4.5 Manual control switch VD Up / Down and memory

Kable length	2'000 mm
Ambient temperature	0 – 40 °C
Protection class (DIN EN 60529)	IP 30

2 Safety requirements

2.1 Explanations of the symbols and notes

Please pay attention to the following explanations of the symbols and notes. They are classified according to ISO 3864-2.

DANGER



Indicates an immediate threatening danger.
Non-compliance with this information can result in death or serious personal injuries (invalidity).

WARNING



Indicates a possible dangerous situation.
Non-compliance with this information can result in death or serious personal injuries (invalidity).

ATTENTION



Indicates a possible dangerous situation.
Non-compliance with this information can result in damage to property or light to medium personal injuries.



NOTE

Indicates general notes, useful operator advice and operating recommendations which do not affect safety and health of the user.

2.2 Basic safety instructions

The safety instructions must be paid attention to. If the system is operated improperly, it can cause danger to people and objects!

It is essential to read this operating instruction thoroughly before commissioning the system. This operating instruction has to be stored in the immediate vicinity of the system.

- In no case the control box may be opened! There is the risk of an electrical shock.
- Modifications or changes to the control box, the manual control switch, the motor and any connection cables are forbidden!
- The control box must only be operated with mains voltage indicated on the name plate!
- The supplied power cable must be used. It is forbidden to operate the control box with a damaged power cable!
- Electrical cables must not be exposed to crushing hazard or to bending and tensile loads.
- Before connecting/disconnecting the manual control switch the power cable has to be disconnected from the mains!
- The control box must not be operated in a potentially explosive atmosphere!
- The control box must be protected from moisture, dripping water as well as spray water!
- The control box is not suitable for continuous use. The operation/hold ratio must not exceed 2/40.
- If there is a failure (for example, if the control drives on its own, or if a push button is stuck) the power cable is to be separated from the mains immediately! The power cable must be freely accessible at any time.
- While using the height adjustment of the work surface there is a danger of squeezing. It is important to make sure that no objects or people are within the danger zone and no one is reaching into the danger zone.
- This device is not intended to be used by people (including children under 8) with restricted physical, sensory or mental abilities or with a lack of experience and/or knowledge, unless they are supervised by a person responsible for safety or they have received instructions by this very person on how to operate the device.
- Children under 8 should be supervised to ensure that they do not play with the device.
- If the power cable of the drive is damaged it must be replaced by the manufacturer, the manufacturer's customer service or by a similar qualified person.
- Only use a dry or a damp cloth to clean the control box! Before cleaning, the power cable has to be separated from the mains!

3 Preparation for first initial operation

Before commissioning the lifting system, the entire system must be assembled correctly according to the assembly instruction. Commissioning is prohibited until the entire system complies with the provisions of EG Machinery Directives 2006/42/EG. For this, a risk analysis of the complete system must be carried out so that you can react to possible residual dangers (for example by constructive measures or by instructions in the operating instructions and/or by safety instructions on the system).

3.1 Mounting the control box and connecting the cables

Mounting of the control box underneath a table top:

ATTENTION



During mounting of the control box the power cable needs to be disconnected from the mains!

1. Place the control box to the desired location and mark the drill holes with a pen.

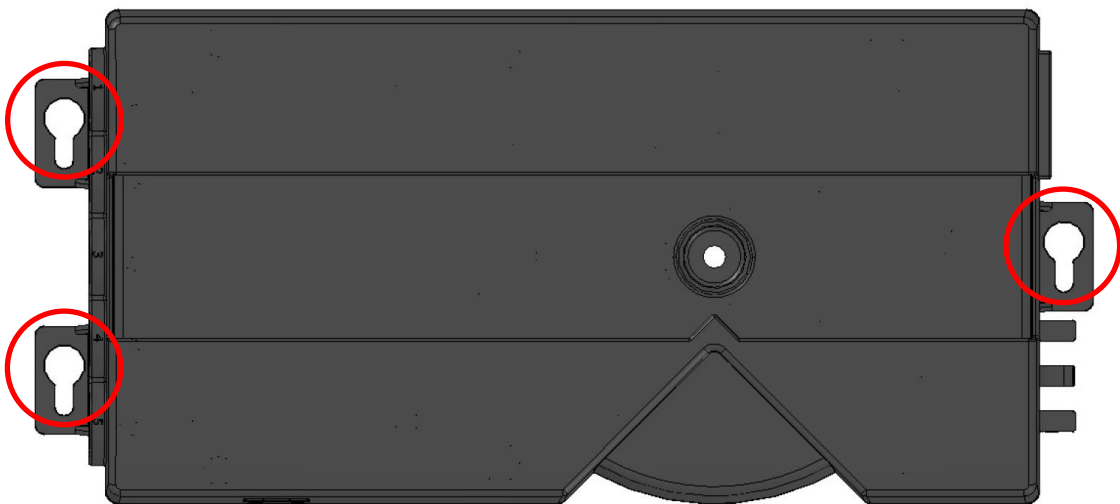

2. Pre-drill two holes (\varnothing 3 mm).
Be careful not to drill through the table top!
3. The control box is mounted with three screws.



NOTE

When tightening the screws do not exceed a maximum torque of 2 Nm!



NOTE

The motor cable, connecting the control box to the motor, has a length of 2'000 mm. If needed, up to 2 motor extension cables can be connected. They have a length of 1'500 mm.
→ 124.0237: VD Extension cable 1'500 mm Motor

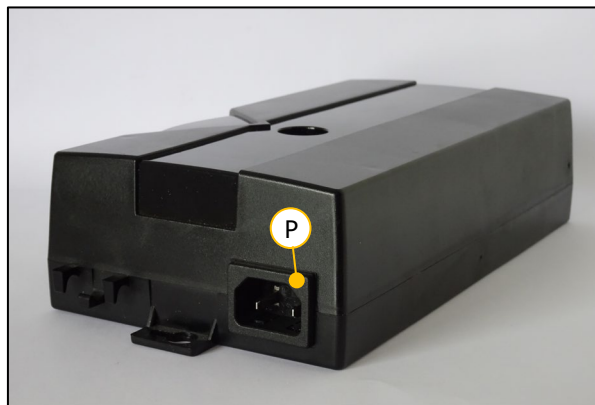
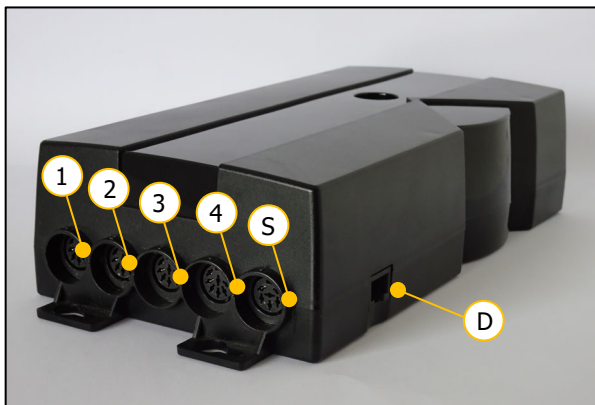

① - ④ Motor socket 1 - 4

(D) Connection for safety strip or sync cable

(S) Socket for manual control switch

(P) Power socket

ATTENTION



Connecting homemade products to the control box is prohibited!

1. Connect the motor cable to the control box. *(Please follow the order M1-M4!)*
2. Connect the manual control switch to the control box.
3. Connect the power cable to the control box.
4. Connect the power cable to the mains. (Clicking sound → ready for initial operation)

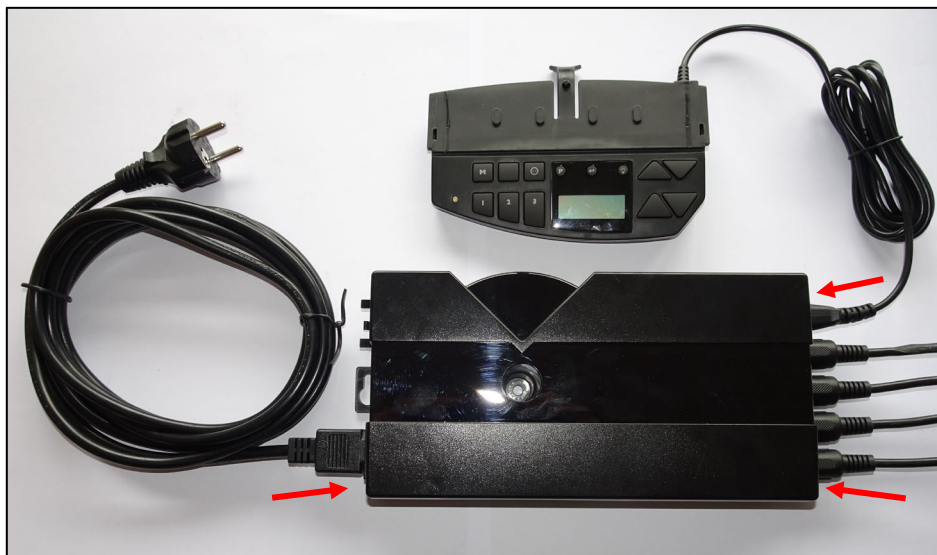

NOTE



Before connecting the power cable to the mains the following must be verified:

- Does the mains voltage correspond to the value on the name plate of the control box?
- Are the plugs of the motor cable connected to the correct sockets (M1-M2)?
- Is the entire lifting system assembled according to the assembly instructions?

3.2 Mounting of the manual control switch

3.2.1 Manual control switch VD Up / Down

1. Position the manual control switch at the desired location underneath the table top.
The control panel must overhang below the work surface!
2. Fasten the manual control switch using the mounting screws.
Be careful not to drill through the table top!

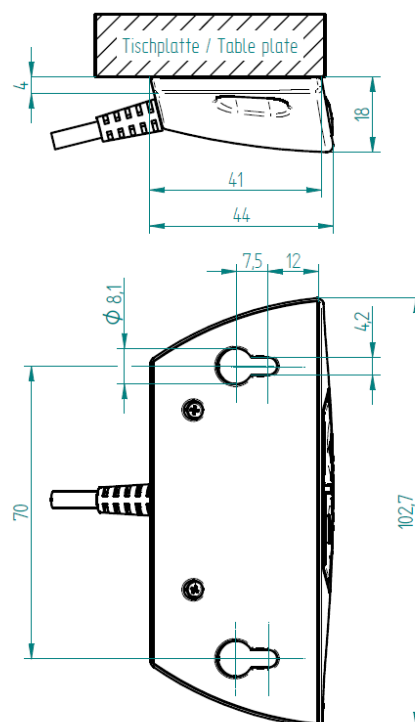

3.2.2 Manual control switch VD / Memory

1. Position the mounting plate underneath the table plate.
The control panel must overhang below the work surface!
2. Fasten the mounting plate using the mounting screws. Be careful not to drill through the table top!
3. Slide the manual control switch onto the mounting plate.

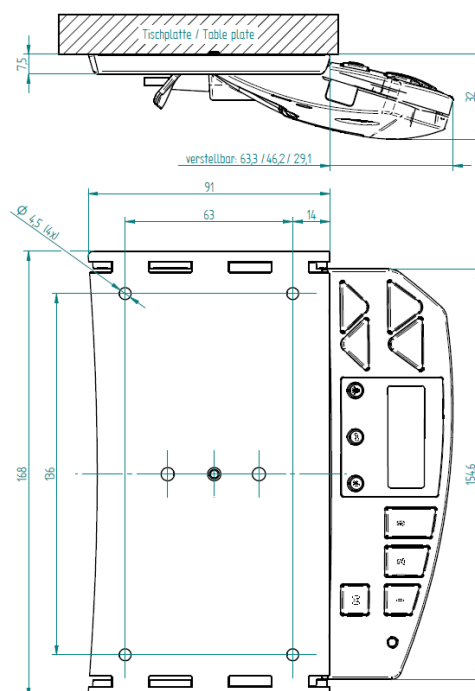

3.2.3 Manual control switch VD Memory T6

1. Position the manual control switch at the desired location underneath the table top.
The control panel must overhang below the work surface!
2. Fasten the manual control switch using the mounting screws.
Be careful not to drill through the table top!

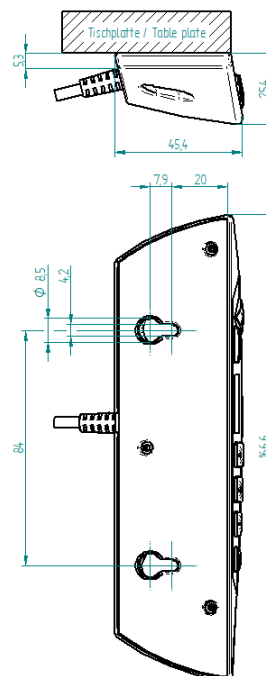

4 Initial operation

ATTENTION



Before commissioning the lifting system, the entire system must be assembled correctly according to the assembly instruction. Commissioning is prohibited until the entire system complies with the provisions of EG Machinery Directives 2006/42/EG. For this, a risk analysis of the complete system must be carried out so that you can react to possible residual dangers (for example by constructive measures or by instructions in the operating instructions and/or by safety instructions on the system.)

ATTENTION



While using the height adjustment of the work surface there is a danger of squeezing. It is important to make sure that no objects or people are within the danger area and no one is reaching into the danger zone.

ATTENTION







The lowest block position must always be reachable. The lifting element is not allowed to hit a stop before it reached its lowest block position. Otherwise the reference will be stored at a wrong height.



NOTE

During the initial operation the control box works with only half power and half speed. The system should be fully loaded after finishing the initial operation.

1. Keep the buttons  and  pressed simultaneously to drive to the under block position. The system moves downwards at half speed. Upward movement is disabled.
 2. After reaching the block position, let go of the buttons  and .
- The control box will give a click-sound and the system will drive out a few millimeters.

After reaching the block position, the lower and the upper position will be stored automatically. The initial operation is completed.

(The lower position is 3 to 4 mm higher than the block position. The upper position depends of the lifting element type, resp. of the control box software.)

5 Operation

5.1 Drive up / down

This function is used for easy height adjustment of the system.

- Press the button  or .
Keep the button pressed until the desired working height is reached.



5.2 Duty cycle monitoring

The duty cycle monitoring checks for the operation/hold ratio. To avoid overheating of the system a duty cycle of 2/40 (ON/OFF) should be maintained.

The maximum continuous operating time is 2 minutes. Afterwards a pause of at least 40 minutes needs to be observed before the system can be operated again.

5.3 Saving a memory position (Only with manual control switch type Memory!)



With this function it is possible to memorise a certain position/height and approach it at a later time by pushing one button. With the three memory buttons up to three different positions can be stored and approached.

1. Drive to the desired position and press the button **M** 3 times.
2. Press one of the buttons   .

A signal tone will ring after saving the memory position.
This operation can be repeated as often as you like and on any position.

5.4 Approaching a stored position (Only with manual control switch type Memory!)

This function is designed to approach a stored position.



- Keep one of the buttons    pressed.
The system approaches and stops at the stored position.

5.5 Container-Stop and Shelf-Stop-positions (Only with manual control switch type Memory!)

These two features can be used to limit the movement area of the lifting system (e.g. if a container is placed underneath the desktop).

A Container-Stop position will be the new lowest end position, a Shelf-Stop position will be the new highest end position.

To define a Container-Stop/Shelf-Stop position, proceed as follows:

1. Press the button **M** 8 times -> A signal tone will ring.
2. Drive to the desired position and press the button **M** 3 times.
3. Press the button  **or** the button  -> A signal tone will ring.



NOTE

If the button  is pressed, the upper position will be limited = **Shelf-Stop**

If the button  is pressed, the lower position will be limited = **Container-Stop**



NOTE

For a Container-Stop position and Shelf-Stop position, these steps must be performed separately.

To deactivate an existing Container-Stop/Shelf-Stop position, follow the same procedure and redefine the new end position.

5.5.1 Child-proof lock (Only with manual control switch type Memory!)

Activate child-proof lock:

- Press the button **M** for 10 seconds.

The control box signals the activation of the child-proof lock with a signal tone.

When the child-proof lock is activated, any

Pressing any button on the manual control switch will show the warning A 101 or A 65 on the display.



Deactivate child-proof lock:

- Press the button **M** for 10 seconds.

The control box signals the deactivation of the child-proof lock with a signal tone.

The system can now be operated normally.

5.6 Reset of the control box

1. Drive the system to the programmed lowest position.
2. Keep the buttons  and  pressed simultaneously.
System will drive to the lower block position and adjust itself like during the initial operation.

6 Synchronous operation of 2 control boxes

6.1 Cable connections

With the SYNC-2 cable VD (124.00183) two control boxes can be connected and synchronised. The length of the SYNC-2 cable VD is 4'000 mm. The SYNC cable cannot be extended. If necessary, the motor cables can be extended!

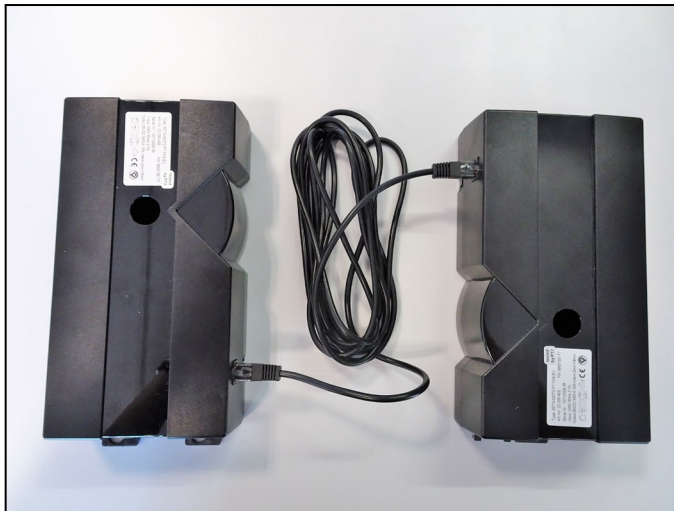

NOTE
Use the upper slot!



NOTE
Always do a reset before disconnecting!
Disconnect the plug carefully -> risk of damage

6.2 Commissioning the synchronized system

1. Connect the drives according to the manual.
2. Connect the control boxes using the SYNC-2 cable VD.
3. Connect the manual control switch to one of the two control boxes.
4. Connect the control boxes to the mains.
(clicking sound of the control box -> ready for initial operation)
5. Carry out the initial operation according to chapter 4.

ATTENTION



The SYNC cable must be connected to the control box before the control box is connected to the mains. If the SYNC cables are connected afterwards, they will not be recognised by the control box and only one drive will move, which can lead to jamming of the entire system.

7 Safety strip - Squeezing protection

With lifting systems of Ergoswiss AG it is important to make sure that no objects or people are trapped during the lifting movement. -> **Danger of squeezing**

Attach the safety strip to an assumed squeeze zone. If the safety strip gets squeezed while the system moves, the motor will stop instantly and turn back for 14 motor turns.

The safety strip VD cpl. (124.00156) consists of:

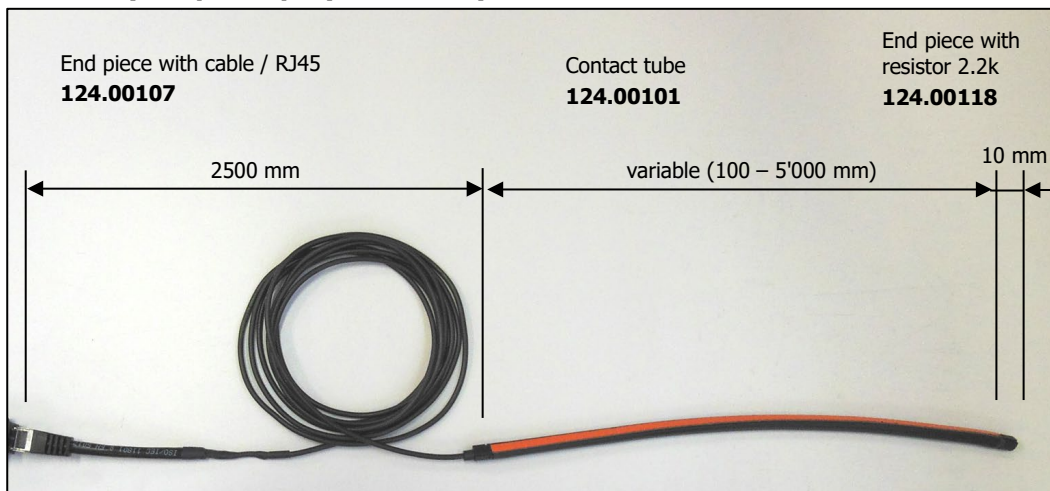

7.1 Technical Data

Functional properties of the contact tube

Contact angle	< 80 °
Switching pressure	< 25 N bei 23 °C
Switching travel	< 2 mm bei 23 °C
Bending radii minimal	B ₁ 120 mm / B ₂ 150 mm B ₃ 20 mm / B ₄ 20 mm
Max. tensile load	20 N

Electrical properties

Terminal resistance	2.2 kOhm
Max. switching capacity	250 mW
Max. voltage	DC 24 V
Current min. / max.	1 mA / 10 mA

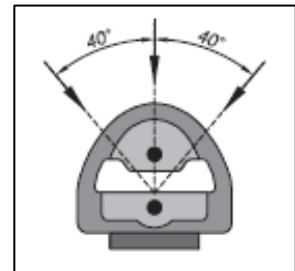
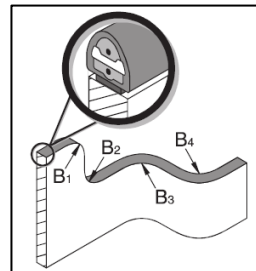

Gluing the contact tube in the squeeze zone	Connecting the safety strip
<ol style="list-style-type: none"> 1. Clean and degrease the contact face 2. Pull off a liner of acrylic foam of 10 to 15 cm 3. Place it on the contact face and press on well 4. Repeat steps 2 and 3 until the contact tube is completely glued on 5. Maximum adhesion is reached after 24 h 	<ol style="list-style-type: none"> 1. Run the cable 124.00107 orderly to avoid entanglement 2. Connect the adapter plug to the control box 3. The safety strip must be connected to the control box before the control box is connected to the mains. If the safety strip is connected afterwards, it will not be recognised by the control box!

8 Maintenance and disposal

8.1 Maintenance and cleaning

The lifting system is maintenance-free for up to 10'000 cycles while observing the specified normal operation. Therefore, servicing is not necessary.

ATTENTION



The control box and the manual control switch must only be cleaned with a dry or damp cloth. Before cleaning the power cable has to be separated from the mains.

ATTENTION



No liquid is allowed to enter the plug connections.

8.2 Repairs and spare parts

Repairs must only be conducted by specialists. Only original replacement parts may be used. For all repair work the system must always be unloaded and voltage-free.

ATTENTION



In no case may the control box be opened! There is the risk of an electrical shock.

8.3 Disassembly and disposal

When decommissioning and disposing of the lifting system the electronic parts must be disposed of separately. The system consists of components that can be fully recycled and thus they are quite safe from an environmental protection perspective. The electronic parts comply with the RoHS directive.

8.4 Electrical and Electronic Equipment Act

The lifting system is not covered by the Electrical and Electronic Equipment Act (WEEE Directive 2012/19/EU), since the lifting system – in accordance with the intended purpose use – is not intended for end-users (business-to-customer) but for industrial applications (business-to-Business) is designed.

8.5 Error messages on the display (Only with manual control switch type Memory!)

Display 4 digits	Display 3 digits	Cause	Rectification
A 0	A 0	SC-reset OK	
A 99	A 63	THD-display error	
A 100	A 64	Reset enforcement	Perform a reset.
A 101	A 65	Child-proof lock	Child-proof lock is activated. To move system, please deactivate the child-proof lock.
A 105	A 69	Safety strip is missing	Safety strip is not connected or defect. Connect the safety strip correctly or replace it.
A 111	A 6F	Movement monitoring	System overloaded → Remove load from the system System jammed → remove clamped object Motor not connected correctly → connect motor cables correctly Drive in opposite direction for a short time.
A 112	A 70	Hall sensor -> no signal	
A 113	A 71	Hall sensor -> wrong motor movement	
A 114	A 72	Motor missing -> no connection	
A 115	A 73	Motor missing -> no power	
A 201	A C9	Lock -> duty cycle monitoring	The drives were operated longer than allowed. The system stopped automatically to avoid overheating. Wait a few minutes till the system has cooled down, then the system is ready again.
A 202	A CA	Overheat	
A 215	A D7	Overcurrent motor	
E 105	E 69	Short-circuit -> safety strip	
E 106	E 6A	Short-circuit -> hand switch	The control box recognized a short-circuit at the hand switch connection socket. Replace the defect hand switch with a new one and perform a reset.
E 212	E D4	Short-circuit -> hall sensor	The control box recognized a short-circuit at the hall sensor of one or more motors. Replace the defect motor with a new one and perform a reset.
F 215	F D7	Short-circuit -> motor	The control box recognized a short-circuit at the supply voltage of one or more motors. Replace the defect motor with a new one and perform a reset..
F 222	F DE	EEPROM error	
F 233	F E9	MOSFET defect	

8.6 Trouble-shooting

Error	Cause	Rectification
Drive does not work	Control box not connected	Connect power cable
	Motor not connected	Connect motor cable
	Motor defective	Contact the customer service
	Control box defective	Contact the customer service
	Manual control switch defective	Replace the manual control switch
	Bad connector contact	Plug in all plugs correctly
Drive only move to one direction	Control box defective	Contact the customer service
	Manual control switch defective	Replace the manual control switch
Drive only moves downwards	System overload	Remove weight from the system

9 Declaration of Incorporation

EG-Declaration of Incorporation in the sense of the Machinery Directive 2006/42/EG annex II 1B

We hereby declare that for the incomplete machine "spindle lifting system", for ergonomically height adjustable workplaces or similar, with the variants

Lifting system SLA xxxx VD
Lifting system SLG xxxx VD

(Art. Nr. 903.2xxxx)
(Art. Nr. 904.2xxxx)

the following essential requirements of the Machinery Directive 2006/42/EG are applied and complied with:

1.1.2.; 1.1.3.; 1.1.5.; 1.1.6.; 1.2.; 1.3.2.; 1.3.9.; 1.5.1.; 1.5.3.; 1.5.7.; 1.5.8.

In particular the applied harmonized standards:

EN 1005	Safety of machinery: Physical performance
EN ISO 12100	Safety of machinery: 2011
EN 60335	Safety of electrical appliances for household use
EN 61000	Electromagnetic compatibility: EMC
EN 60950	Security of information technology equipment

specific technical documentation have been created in accordance with annex VII, part B, and will be sent to the national authorities by registered letter or electronically, if the request is justified, and this incomplete machine is in conformity with the relevant provisions of other EU Directives:

89/391/EG	Safety and health of workers
2001/95/EG	General product safety
2014/30/EU	Directive on electromagnetic compatibility
2014/35/EU	Low voltage directive

Furthermore, we declare that this incomplete machine may only be commissioned if it has been determined that the machine in which the incomplete machine is to be installed complies with the provisions of the Machinery Directive 2006/42/EG and our assembly and service operating instructions have been followed.

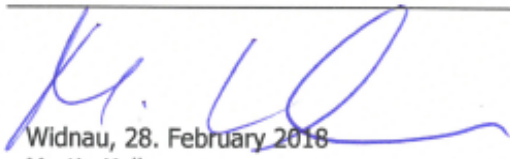
Widnau, 28. February 2018
Martin Keller
Managing Director / CEO

Document responsibility EU:

Ergoswiss Deutschland GmbH
Weiherstrasse 6/1
DE-72585 Riederich